



## ROUND THE WORLD PANNIERS™ PACKING TIPS

- Do not overstuff or over-load RTW Panniers. The challenge should be to pack as little as necessary to be safe, comfortable and self-sufficient. Go light. Go fast. Go far.
  - Take care to pack the heaviest gear as low as possible, preferably below the seat line, with weight balanced from side-to-side. Your bike will handle far better with weight positioned as close to the center of the bike as possible.
  - For maximum water protecting, roll top three folds. In drier conditions, Panniers and pockets can be expanded by rolling top just once.
- NOTE:** Exterior roll-top pockets are highly water resistant but not waterproof - pack gear accordingly.
- To avoid wearing through the RTW Panniers and inner waterproof Dry Pods from vibrations, pack all sharp and/or hard items inside a protective layer. For example, create a sleeve for tire irons from a section of old inner tuber, pack tools in rolls and wrap other hard items in clothing.
  - Use compression wings and straps to secure additional lightweight items to outside of bag. Secure items so they cannot work loose and fall out.
  - Visit our website at GiantLoopMoto.com for more tips from riders and instructions.



### RECOMMENDED OPTIONAL ACCESSORIES

**Columbia Dry Bag**  
Mounts securely on top of luggage racks to add another 70 liters.



**84" QuickLoop Security Cable**  
Add peace of mind by locking Panniers to parked motorcycle.



### TERMS OF USE, LIMITED LIFETIME WARRANTY AND LIABILITY WAIVER

Giant Loop LLC, an Oregon company, having its principal place of business in Bend, OR ("Giant Loop") offers its motorcycle bag (the "Product") with the terms, conditions and notices as follows:

#### TERMS OF USE

This Product is offered to you conditioned upon your acceptance without modification of the terms, conditions, and notices contained herein. Installation and/or use of this product implies acceptance of all such terms, conditions, and notices. If you do not agree to these terms, do not buy the Product. If you have already bought the Product and do not agree to these terms, return this Product promptly, including the packaging and all written materials, to Giant Loop.

#### LIMITATION OF LIABILITY AND LIMITED LIFETIME WARRANTY DISCLAIMER

Giant Loop offers a money-back guarantee provided the Product is returned, in unused condition with original receipt, within 30 days of purchase. Giant Loop reserves the right to subtract a 15% re-stocking fee from the refund amount. Standard shipping fees will apply to exchanged items and are paid by the customer. If you receive damaged or defective goods or items that you did not order, the items must remain unopened and unused so we can credit you in full, including return shipping if it is a result of our error, mishandled shipping or manufacturer's defect.

Giant Loop provides to the original purchaser a limited lifetime warranty against defects in materials or craftsmanship if purchased directly from a Giant Loop authorized dealer. This warranty covers defective materials and craftsmanship only, and does not include damage due to normal wear and tear or misuse. Failure to comply with the included instructions for this Product will void the limited lifetime warranty. If defects in the materials or craftsmanship of the Product exist, notify Giant Loop immediately of the defect. Giant Loop will provide for repair or replacement of the Product, after Giant Loop has determined, in our sole discretion, that a defect is present. Proof of purchase is required to utilize the limited warranty provisions.

If you experience any problems with the Product within the warranty period please return the Product or contact us for prompt repair or replacement at our discretion: ride@giantloopmoto.com, 458-206-9113.

Excepting the warranties stated in the preceding paragraph, Giant Loop hereby disclaims all other warranties and conditions with regard to the Product including all implied warranties and conditions of merchantability and fitness for a particular purpose. There are no warranties which extend beyond the description on the face hereof. Giant Loop does not warrant against damages or defects arising out of use or installation of the Product. Installation instructions are provided for your convenience. Giant Loop is not responsible for any damages arising out of the installation, improper or otherwise, of the Product. No warranty of any kind, expressed or implied, is made regarding the safety of this Product.

To the extent allowed by law, Giant Loop shall not be held liable for any direct, indirect, punitive, incidental, special or consequential damages arising out of, or connected with, the use or misuse of this Product. Buyer assumes all risks and liability arising from use of this Product.

#### ENTIRE AGREEMENT

This document states the entire obligation of Giant Loop with respect to the Product. If any part of this agreement is determined to be void, invalid, unenforceable or illegal, including, but not limited to the warranty disclaimers and liability limitations set forth above, then the remainder of the agreement shall remain in full force and effect.

#### APPLICABLE LAW

This agreement is governed by the laws of Oregon, USA. You hereby consent to the exclusive jurisdiction and venue of the courts of Oregon, USA, in all disputes arising out of or relating to the use of this product.

Please keep in touch. We want to hear about your adventures!

Giant Loop LLC  
Bend, Oregon USA  
ride@giantloopmoto.com

458-206-9113  
GiantLoopMoto.com



## ROUND THE WORLD PANNIERS™ MOUNTING INSTRUCTIONS

GL Part No. RTW16  
Tucker Rocky Part No. 804883



### GIANT LOOP ADVENTURE PROOF PACKING SYSTEMS & GEAR: ADVENTURE TOURING

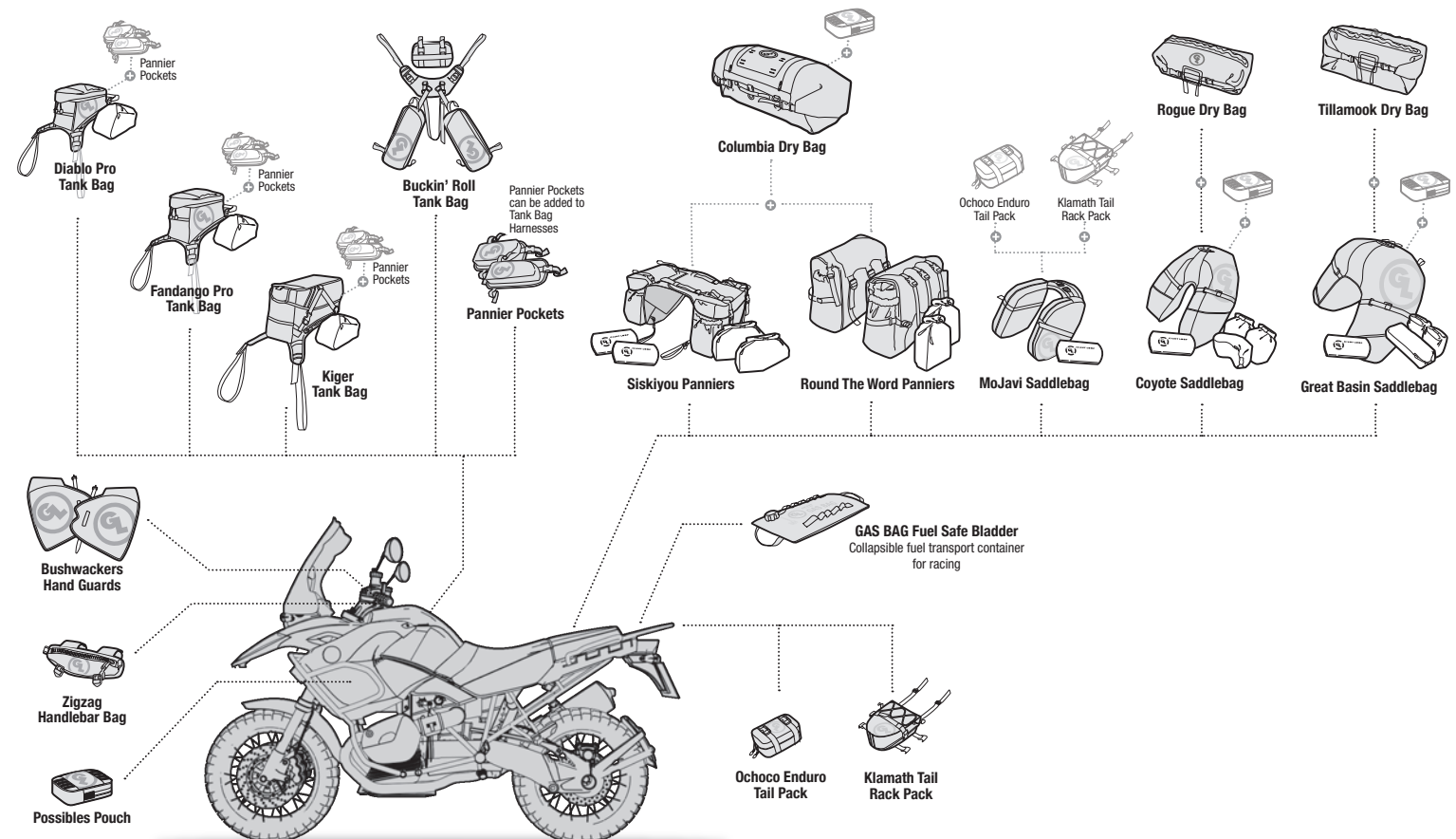



# ROUND THE WORLD PANNIERS™

## MOUNTING INSTRUCTIONS

**NOTE:** Failure to follow recommended mounting and installation instructions voids warranty. Manufacturer is not liable for any damage, injury or death that results from improper use and installation of products. By installing these products, user accepts all liabilities, terms and conditions outlined in the Liability & Warranty statement included here.

### PRE-FITTING & QUICK MOUNTING YOUR ROUND THE WORLD PANNIERS™

#### 1 PRE-FITTING

Connect RTW Panniers with cross-over straps and drape over back of bike and luggage rack. Check fit considerations, such as room for passenger's foot in front of pockets, proximity to hot exhaust, etc. RTW Panniers can be mounted with either the roll-top pocket or the drawstring pocket facing forward.

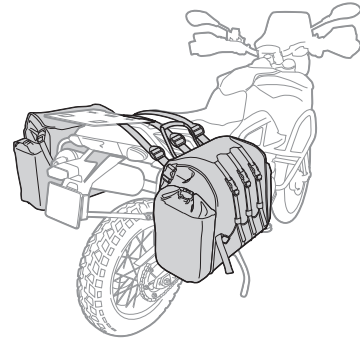

#### 2 REMOVE FRAME SHEETS

Inside of RTW Panniers pull open frame sheet covers and remove HDPE internal frame sheets. The frame sheets will be used to align your luggage rack system's mounting hardware and Pannier position on the luggage rack.

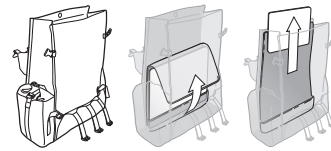

#### 3 FITTING TEMPLATE

Use the included template to help determine drill hole locations for mounting hardware. The shaded area is the NO DRILL ZONE. Avoid locating drill holes and mounting hardware inside this shaded area.

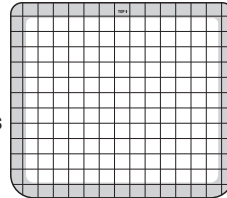

#### 4 ALIGN TEMPLATE AND FRAME SHEET TO RACK

Tape template to frame sheet.

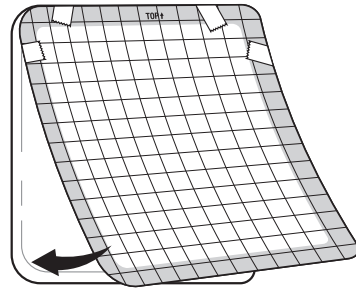

#### 5 MARK LOWER MOUNTS FIRST

Working from the wheel side, mark the positions of the two lower mounts.

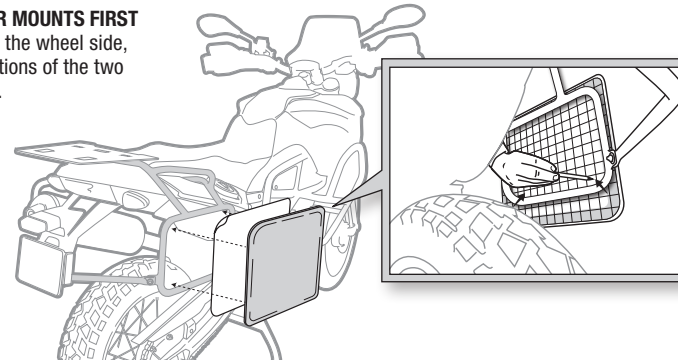

#### 6 DRILL LOWER MOUNT LOCATIONS

Drill through frame sheet in the locations marked for the two lower mounts.

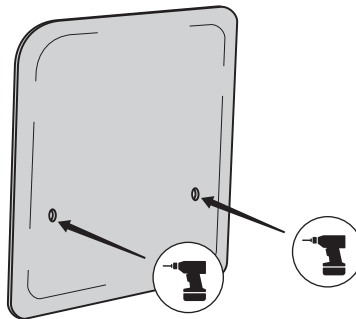

#### 7 CONFIRM FIT

Thread mounting hardware through frame sheets and confirm fit on side luggage racks. If necessary, adjust drill hole locations. **DON'T PANIC** if you need to drill additional holes - just try to leave a little material between holes if possible.

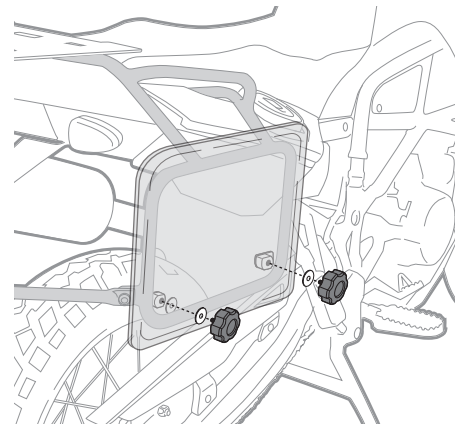

#### 8 MARK THE UPPERS

Once the lower mount locations are confirmed, use hardware to hold the frame sheet in place while marking locations for upper mounts.

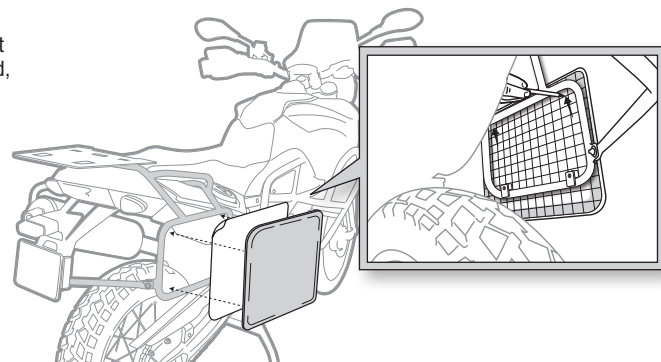

#### 9 DRILL THE UPPERS

Drill through frame sheet in the locations marked for the two upper mounts.

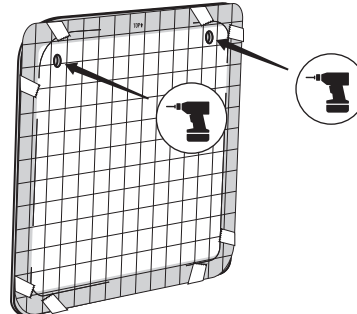

#### 10 CONFIRM FIT ON UPPERS AND LOWERS

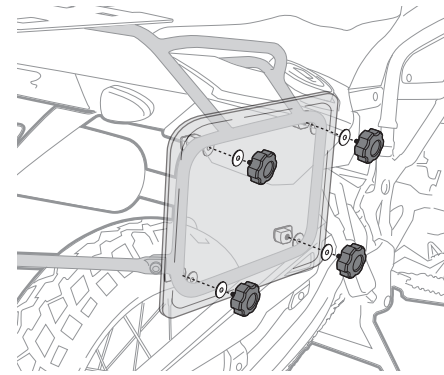

#### 11 SECOND FRAME SHEET ALIGNMENT

Remove all temporary hardware (A). Place second, undrilled frame sheet under drilled frame sheet (B). C-clamp together, mark, drill (C).

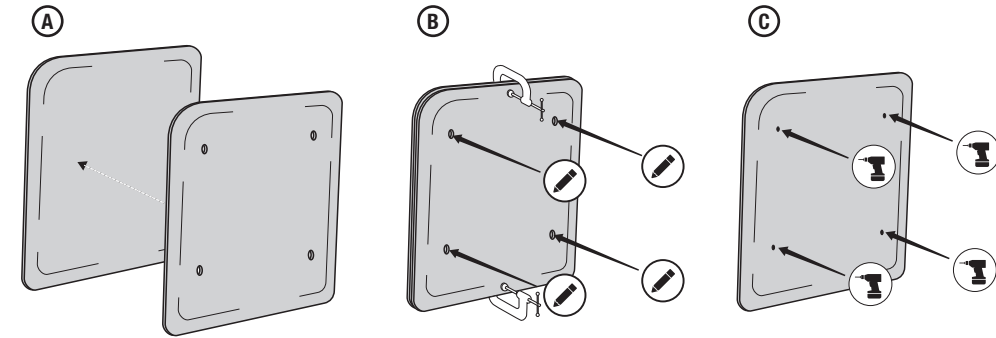

#### 12 ALIGN AND MARK FRAME SHEET

Re-insert frame sheet into Pannier. Feel the edge of the frame sheet inside to position the second frame sheet on the outside of the Panniers, using it to mark hole locations where the mounting hardware passes through the Pannier. Repeat on second Pannier.

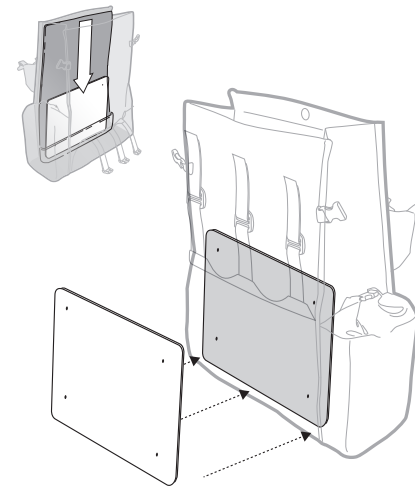

#### 13 MELT HOLES IN RTW PANNIERS

In a well ventilated space, use hot soldering iron to carefully melt holes through fabric on wheel side of Panniers. If you do not have a soldering iron, the holes may be burned with a nail held with locking pliers and heated with a torch, or carefully drilled. Make holes just large enough for hardware to pass through fabric.

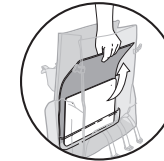

Hold frame sheet covers out of the way.

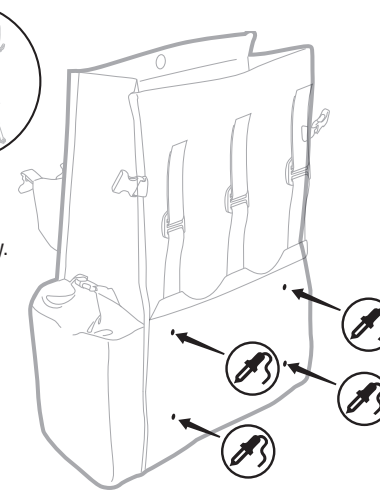

#### 14 SECURE RTW PANNIERS TO LUGGAGE RACKS

Install frame sheets and mounting hardware in Panniers. Secure Panniers to side luggage racks. Double check all connections before riding. Periodically check and re-tighten mounts if needed while riding. Always close and secure all fasteners and webbing strap ends before riding.

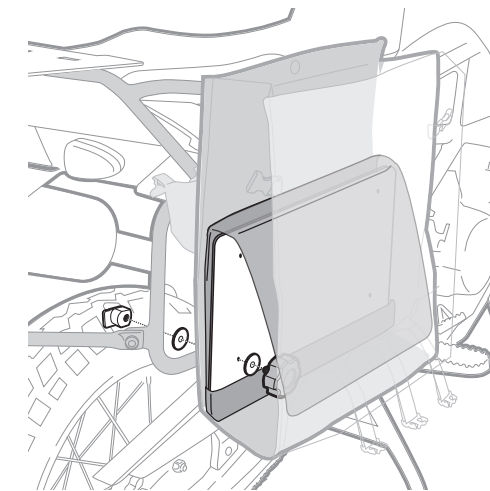

#### 15 MOUNTING ALTERNATIVES AND REMOVING CROSS-OVER STRAPS

On some racks, the cross-over straps can be used under seat and tail rack to help support the RTW Panniers. **WE DO NOT RECOMMEND USING THE RTW PANNIERS WITHOUT ADEQUATE STRUCTURAL SUPPORT TO PREVENT PANNIERS FROM GETTING INTO REAR WHEEL.**

If cross-over straps are not needed, remove them from buckles. When Panniers are removed from bike, cross-over straps can be used for hands-free carrying.

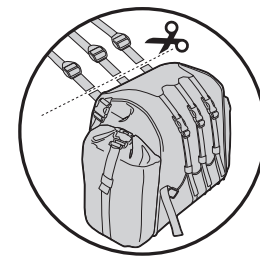

If you do not intend to use the cross-over straps, the buckles can be trimmed off with scissors. Use a lighter to singe webbing ends to prevent fraying.

